

# Automated Guided Vehicles/ Self Guided Vehicles

## ➤ Chapter 7

## ➤ Topics

- History
  - What is AGVs /AGVSs
  - Components of AGVS
  - Types of AGVS
  - Important issues for the AGVS
  - Design Features
  - System design of AGVS
- 

# Automated Guided Vehicle System

- Transport material from loading to unloading stations
- Highly flexible, intelligent and versatile material-handling systems.
- A very flexible solution for the problem of integrating a new automated transportation line into an existing transportation environment by using automatic guided vehicle.

# History

- First AGV developed in 1954 by A.M.Barrett,Jr.
- Using a overhead wire to guide a modified towing truck pulling a trailer in a grocery warehouse.
- Subsequently, commercial AGV were introduced by Barrett.
- 1973, Volvo developed automated guided vehicles to serve assembly platforms for moving car bodies through its final assembly plants.
- Later, Volvo marketed their unit load AGVs to other car companies.

# What is AGV?

- Driverless Vehicle
  - Electric motors, battery powered
  - Programming capabilities
    - Destination
    - Path selection
    - Positioning
    - Collision avoidance
  - System Discipline
- 

## Modern AGVS

- Modern AGVs are computer-controlled vehicles with onboard microprocessors.
- Position feedback system to correct path
- Communication between vehicles via system controller
  - RF communication
  - Electric signals
- System management computers
- Optimising the AGV utilisation
- Tracking the material in transfer and directing the AGV traffic.



**SPECIFICATIONS:**



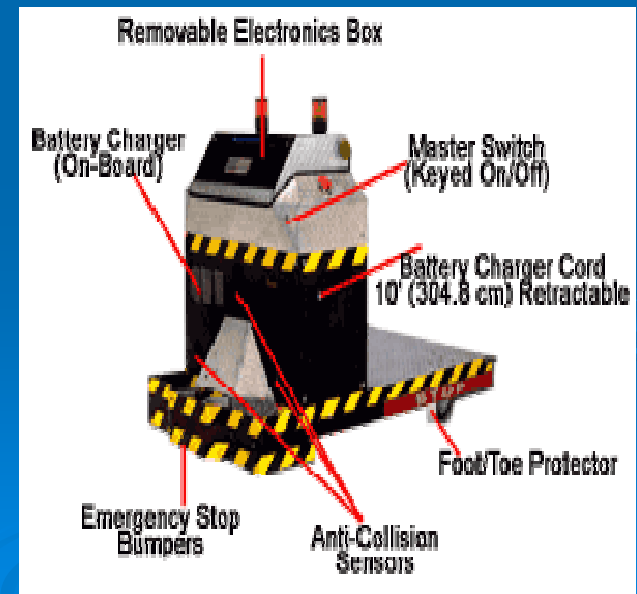
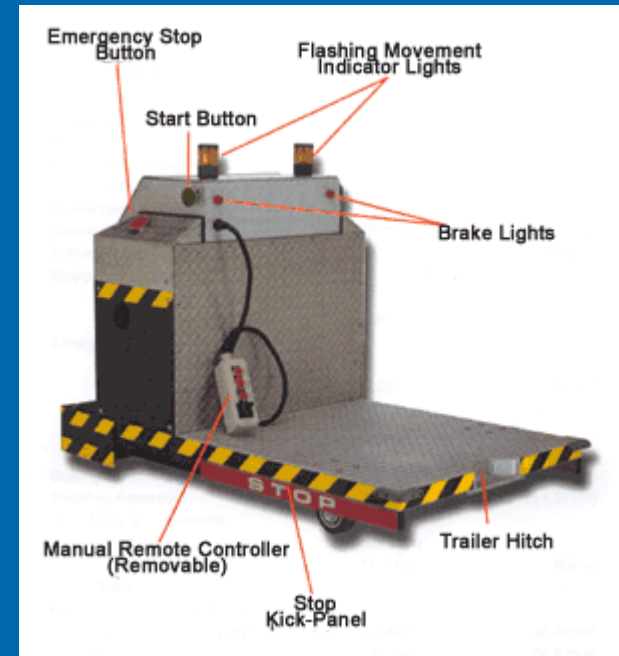





<b>Length</b>	63.25"	(160.7cm)
<b>Width (with kick panels)</b>	34.50"	(87.6 cm)
<b>Height (Overall)</b>	42.5"	(107.0 cm)
<b>Height (Platform)</b>	7.625"	(19.4 cm)
<b>Platform Size</b>	36" x 34"	(91.5 cm x 86.4 cm)
<b>Weight (without batteries)</b>	302 lbs	(137.3 kg)
<b>(with batteries)</b>	526 lbs	(239.1 kg)
<b>Frame Load Capacity</b>	1,300 lbs	(590.9 kg)
<b>Castor Capacities (up to )</b>	1,800 lbs ea	(818.2 kg)
<b>Turning Radius (standard)</b>	36"	(91.5 cm)
<b>Stopping Accuracy (programmed)</b>		
<b>Loaded w/780 lbs (354.5 kg) or Unloaded</b>	<.5"	(<1.3 cm)
<b>Emergency Braking Accuracy:</b>		
<b>Unloaded @ 120 fpm (36.6 meters/minute)</b>	<.25"	(<.64 cm)
<b>Loaded w/804 lbs (365.4 kg) @ 120 fpm (36.6 meters/minute)</b>	<5.0"	(<12.7 cm)
<b>Queing Accuracy (adjustable)</b>	+/-1.25"	(+/-3.2 cm)
<b>Tracking Accuracy</b>	+/- .5"	(+/- 1.27 cm)
<b>Drive Motor Specifications:</b>		
<b>Output</b>	300 watts	
<b>Load Capacity</b>	1325 lbs	602 kg
<b>Gear Ratio</b>	24.0:1	
<b>Speed (Programmable from 0-180 fpm)</b>		
<b>Automatic (standard)</b>	120 fpm	36.6 mpm
<b>Manual</b>	180 fpm	54.9 mpm



*Details from Paragon, Inc.*

# Components of AGVS

- The Vehicle – No operator
- The guide path – The path for the AGV
- The control Unit – Monitors and Directs system operations including feedback on moves, inventory, and vehicle status.
- The computer interface – Interfaces with other mainframe host computer, the automated storage and retrieval system (AS/RS), and the flexible manufacturing system.

VEHICLE FEATURES		SYSTEM FEATURES	
	<p><b>LASER NAVIGATION</b></p> <p>Laser navigation utilizes a vehicle mounted rotating laser head. The laser head emits a signal which is returned to the receiver by reflective "targets" that are mounted in the area. From this information, the exact vehicle heading and position is calculated.</p> <p>Laser navigation offers the ultimate in accuracy and flexibility with unlimited path changes that can be implemented instantaneously with no floor cutting or drilling.</p>		<p><b>SGV MANAGER</b></p> <p>The SGV Manager software is a user-friendly graphical tool that controls the SGV System. This control software manages vehicle orders, provides traffic control, interfaces with plant equipment/software, provides automatic backup, and allows viewing system operation (realtime or historical playback). It runs on Windows 2000 and can be accessed remotely via a PC on a LAN, modem or RF LAN.</p>
	<p><b>MODULAR VEHICLE FRAME CONSTRUCTION</b></p> <p>Your investment has to start paying off quickly and continue over time. Our modular vehicle frame provides a standard, cost-effective platform that can be customized to your exact specification. The minimum thickness of the vehicle's steel exterior is 1/4", making it extremely rugged to ensure years of reliable operation.</p>		<p><b>INTEGRATION</b></p> <p>For an automated material handling system to be successful, all hardware and software must work together in harmony. Should parts of your system have been supplied by other vendors, EMC Technologies will gladly accept the role of integrating the various components. Whether you are interested in a turnkey project or minor integration of existing systems, EMC Technologies has the experience to ensure the whole package operates together as expected.</p>
	<p><b>VEHICLE CONTROL/DISPLAY</b></p> <p>Every EMC Technologies self-guided vehicle utilizes PC hardware using the Microsoft Windows CE based operating system. These controls drive the vehicle's graphical display. This display contains all the information for operation, maintenance and configuration in a user friendly Windows format. This provides maximum vehicle uptime with minimum personnel training.</p>		<p><b>LAYOUT WIZARD/SETUP WIZARD</b></p> <p>Laser navigation only offers flexibility when there are software tools that can initiate changes to the system. No software tools are better than Layout Wizard and Setup Wizard at delivering the flexibility you need. Changing vehicle paths and optimizing reflective target locations? Layout Wizard is the answer. Changing the routing priorities? Setup Wizard is the answer. Layout Wizard and Setup Wizard give customers the power to adapt as their material handling needs change and grow. All without the time and money required by an outside vendor to complete these tasks.</p>
	<p><b>CONTINUOUS IMPROVEMENT</b></p> <p>As documented in our ISO 9001 Registered Quality System, EMC Technologies self-guided vehicles are designed not only to operate great today, but tomorrow as well. Since we design and manufacture all key components, we are able to ensure that spare part availability and component obsolescence are never a problem.</p>		<p><b>CUSTOMER SUPPORT</b></p> <p>EMC Technologies maintains a dedicated customer service group offering FREE 24 hour technical support for as long as you own your system. By calling 800-362-2280 or 215-822-4590, you'll receive the best support in the industry.</p>

# PUTTING IT ALL TOGETHER

## Wireless Handheld Terminal

1



An operator inputs requests for material movement, or the requests are automatically detected by sensors.

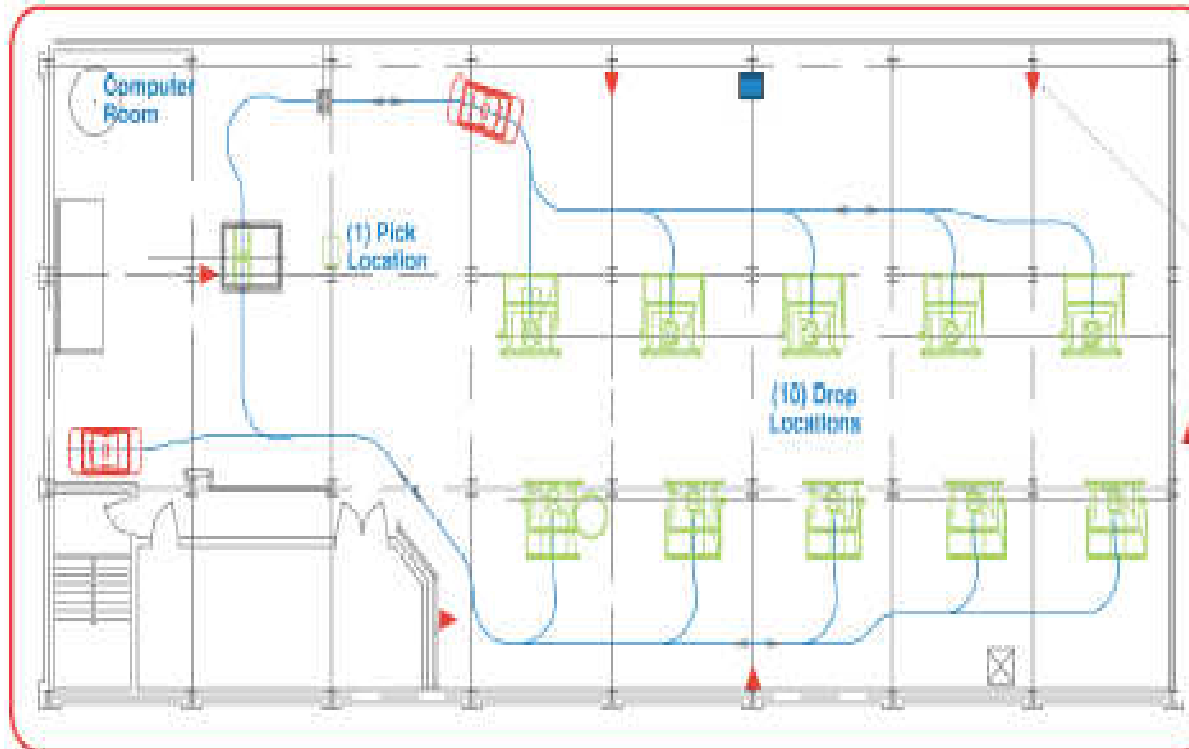

6



## Factory Host Computer

Optional software interface (Serial or LAN) between SGV Manager and the customer's host computer or warehouse management system. Customer's host can initiate and prioritize order and receive feedback on material movement status.

## Reflective Target

Mounted along the vehicle guideway to provide accurate feedback to each SGV for precision navigation.

## RF LAN (Radio System) or Equipment Interface Panel

2



Receives requests and transmits them to the host computer (SGV Manager).

## SGV Manager

3



Assigns movement of material to vehicles, provides traffic control and interfaces with plant equipment.

## RF LAN (Radio System) or Equipment Interface Panel

4



Receives commands from SGV Manager and transmits them to the vehicles and interface equipment (conveyors, doors, elevators, AS/RS, etc.).

## SGV Vehicles

5



Moves loads per instructions from SGV Manager. Navigates through area via Laser Guidance.

# Types of AGVs

- AGVS towing vehicle
- AGVS unit load carriers
- AGVS pallet trucks
- AGVS forklift trucks
- AGVS light-load transporters
- AGVS assembly-line vehicles

## AGVS Towing Vehicles

- First type of AGV introduced.
- Towing vehicle is called an automated guided tractor
- Flatbed trailers, pallet trucks, custom trailers can be used.
- Generally, used for large volumes (>1000 lb) and long moving distances (>1000 feet).



**Load Capacity:**1,500 lbs  
**Vehicle Type:**Laser Guided Tugger  
*AGV Products, Inc*

## AGVS Unit load Carriers

- To transport individual unit load onboard the vehicle.
- Equipped with powered or non-powered roller, chain or belt deck, or custom deck.
- Loads can be moved by Pallet truck, forklift truck, automatic loading/unloading equipment, etc.



**Load Capacity**3,000 lbs  
**Vehicle Type:** Unit Load with variable Height Conveyor

## AGVS Pallet Trucks

- No special device is needed for loading except the loads should be on pallet
- Limited to floor level loading and unloading with palletized load
- Widely used in distribution functions
- Capacity 1000-2000 lb
- Speed > 200ft/min
- Pallet truck can be loaded either manually or automatically

## AGVS Forklift Trucks

- Ability to pickup and drop palletized load both at floor level and on stands.
- Pickup and drop off heights can be different
- Vehicle can position its fork according to load stands with different heights
- Very expensive
- Selected where complete automation is necessary/required.



**Load Capacity:** 1,500 lbs **Vehicle Type:** Laser Guided Fork Lift  
*AGV Products, Inc*

## AGVS Light Load Transporters

- Capacity < 500lb
- To handle light and small loads/parts over moderate distances
- Distribute between storage and number of workstations
- Speed 100ft/min, turning radius 2ft
- For areas with restricted space

## AGVS Assembly-Line Vehicles

- Variation of an light load transporter
- For serial assembly processes
- As the vehicle moves from one station to another, succeeding assembly operations are performed
- This kind provides flexibility for the manufacturing processes
- Lower expenses and ease of installation
- Complex computer control and extensive planning is required to integrate the system.

# Important issues for AGVS

- Guidance system
- Routing
- AGVS control systems
- Load transfer
- Interfacing with other subsystems

# AGVS Guidance system

- The goal of an AGVS guidance system keep the AGV on track/predefined path
- One of the major advantage of AGV is ease in modification given by the guidance system for changing the guide path at low cost compare to conveyors, chains, etc.
- Another benefit is: guide path is flexible which means intersection of path is possible.
- Generally, guide path does not obstruct another systems.
- The guidance systems can be selected based on the type of AGV selected, its application, requirement and environmental limitation.
  - Wire-guided
  - Optical
  - Inertial
  - Infrared
  - Laser
  - Teaching type

## Wire-guided:

- An energized wire is rooted along the guide path.
- The antenna of the AGV follows the rooted wire.

## Optical:

- Colorless florescent particles are painted on the concrete/tiled floor.
- Photosensors are used to track these particles.

## Inertial:

- The guide path is programmed on a microprocessor which is fixed on the AGV
- Sonar system is incorporated for finding obstacles.

## Infrared:

- Infrared light transmitters are used to detect the position of the vehicle.
- Reflectors are affixed on the top of vehicle to reflect the light.

## Laser:

- Laser beam is used to scan wall-mounted bar-coded reflectors.
- Accurate positioning can be obtained.

## Teaching type:

- AGV learns the guide path by moving the required route.
- Sends the information to the host computer.

# AGVS Routing

- A routing system is used to select the vehicle which is positioned with the optimum path.
- A network controller gives the destination, while the on-board controller navigates the vehicle.
- Commonly used methods:
  - *Frequency select method*
  - *Path-switch select method*

# Frequency select Method

- At the bifurcation of path (decision point), the vehicle reads a code in the floor in the form of metal plate, or coded device.
  - The vehicle selects one of the frequencies as per the direction required.
  - The frequencies are always active.
  - A continuous wire is used to loop the frequencies.
- 

# Path-Switch Select Method

- Path is divided into segments.
  - One frequency is used
  - Segments are switched On/Off by separate floor controls according to the path to be followed.
  - Less preferred over Frequency select method.
- 

# AGVS Control Systems

## Computer controlled system

- The path controller controls the guidepath of AGVS. Sends information to AGVS process controller.
- Process controller directs movement of vehicles
- Interchanges information with the host computer
- Most Expensive and complex type of control.

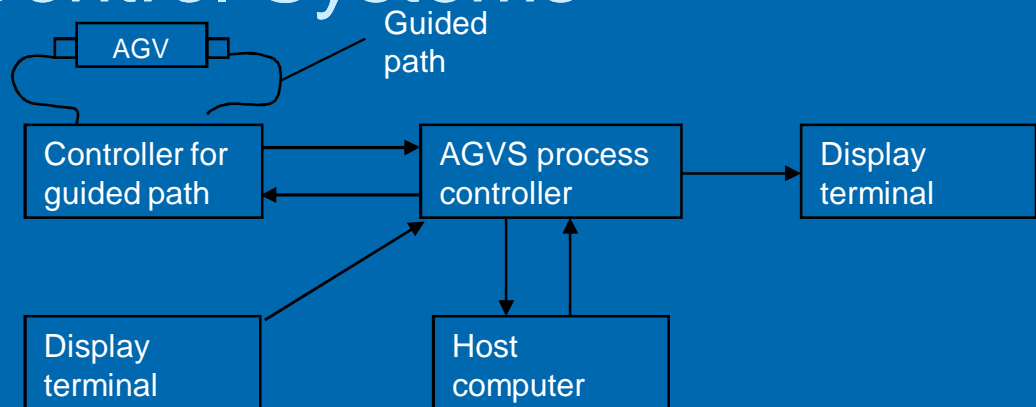

## Remote dispatch control system

- Instructions are issued to vehicle from a remote control station via a human operator.
- Control system sends instruction directly to vehicle.
- The human operator does have the direct control over the vehicles.
- This type of system generally have automatic loading and unloading capability.

## Manual control system

- The destination is fed on the onboard control on the vehicle via a human operator after loading.
- The vehicles moves through the guide path for the destination by itself.
- Reaching destination, it stops for the human operator to direct unloading.
- Least expensive control system.
- Efficiency depends on operators performance and varies.

# AGVS Load Transfer

- Load Transfer of the vehicle means loading/unloading. The two types of load transfer operations are:
  - Manual Load Transfer
    - Manually loading and unloading the Vehicle.
    - Use of forklift trucks, pallet trucks, roller, etc.
    - Manually coupling/uncoupling towed vehicles
  - Automatic Loading and unloading
    - Efficient system
    - Use of Powered roller, belt, and chain
    - Powered lift/lower devices, push/pull devices
    - Automatic couple/uncouple

# Interfacing with other subsystems

- AGVS system can be interfaced with other subsystems through the distributed processing network or using Host computer. Such subsystems are:
  - Automated storage and retrieval system
  - Flexible Manufacturing systems
  - Computer Numerical control (CNC)
  - Process Control Equipment
  - Shop Floor control system

➤ *Case Study*

➤ Videos: <http://www.fmcsqvs.com/index.htm>

From FMC Technologies- Automated Systems

# AGVS DESIGN FEATURES

- Stopping Accuracy:
  - Automatic load transfer- High accuracy
  - Manual load transfer- Low accuracy
  - Unit load transporters are used for systems requiring high accuracy.
  - Feedback system can be used to provide stopping accuracy
  - Depends on the requirement/application.
- Facility:
  - Environmental compatibility, elevator, sensors, etc facilities must be considered while designing AGVS.
- Safety features:
  - Emergency buttons, object detection for collision avoidance, warning signals, must be built into the system.
- Maintenance:
  - Preventive maintenance intervals should be specified.
  - Routine and repair maintenance including lubrication, checking systems electrical/electronic parts .
  - Service manual.
  - Maintenance facilities: Vehicle jack stands, Low-level power indicators.

# AGVS System Design

Many issues must be considered before designing system for an AGVS:

- Selection of guidepath and vehicle
- Guidepath layout / Flow path design
- Number of vehicles

There are several other issues regarding timing of AGVs, dispatching rules, routes, etc. Also, there must be interaction between design and operational issues for system design.

# Attributes for selection of guidance & AGVS

## Vehicle Related attributes:

- Cost of the vehicle system
- Cost of guidance system
- Vehicle dimensions
- Load capacity
  - Maximum weight
  - Maximum Volume (depending on AGV inner dimensions)
- Maximum speed at loaded/unloaded condition
- Maintenance facilities: Modular components for maintenance, self diagnosis, etc.
- Charging related attributes such as charging time, on-line charging.
- Turning Radius
- Position sensors
- Loading system i.e. unit load, pallet, or other attachments required.

# Flow path design

- Type of flowpath within the layout i.e. unidirectional, bidirectional or combination
- Type of guidepath layout
- Position of load transfer or loading /unloading stations
- Number of stoppage stations
- Storage space of the stations.

For developing a flow path design simulation software can be used. These software takes into consideration the layout, locations of P/D stations, timings of AGV, material flow intensities between stations, etc.

# Number of vehicles

General notations:

- $D_d$  = total average loaded travel distance
- $D_e$  = total average empty travel distance
- $N_{dr}$  = Number of deliveries required per hour
- $N_d$  = Number of deliveries per vehicle per hour
- $T_h$  = loading and unloading time
- $T_{dv}$  = total time per delivery per vehicle
- $T_f$  = traffic factor that accounts for blocking and waiting of vehicles and at intersections.

if only 1 vehicle than  $T_f=1$

if Number of vehicles  $> 1$  than  $T_f < 1$

- $v$  = vehicle speed

$$T_{dv} = (D_d / v) + T_h + (D_e / v)$$

= loaded travel time + loading/unloading time + empty travel time

$$N_d = (60 * T_f) / T_{dv}$$

$$\text{Number of automated guided vehicles} = N_{dr} / N_d$$

# Advantages of AGV's

- Unobstructed movement
- Flexibility
  - Locations, path, P/D points can be reprogrammed
  - Easy to change guide path system
  - Number of vehicles can be altered depending on requirement
- Greater reliability
  - Less environmental problems
  - AGV can be replaced by another, in case of failure.
- Lower investment
- Higher operating savings on long run
  - Minimal labor cost
  - Easy maintenance
- Easy to interface with other systems
  - Best choice for AS/RS, FMS

# Automated Storage and Retrieval Systems (AS/RS)

## ➤ Motivation

- An FMS provides an automated cost effective manufacturing set up
- To facilitate the successful running of an FMS system, quick and accurate transportation of the following are required,
  - Parts
  - Pallets
  - Fixtures
  - Tools

# Definition of AS/RS

- Combination of
  - equipment and controls
- Which,
  - Handles
  - Stores
  - and Retrieves
- materials with
  - Precision
  - Accuracy
  - and Speed
- With a defined degree of Automation

# Functions of AS/RS

- Automatic removal of an item from a storage location
- Transportation of this item to a specific processing or interface point
- Automatic storage of an item in a predetermined location
- Automatic reception and processing of items from a processing or interface point

# Typical AS/RS systems

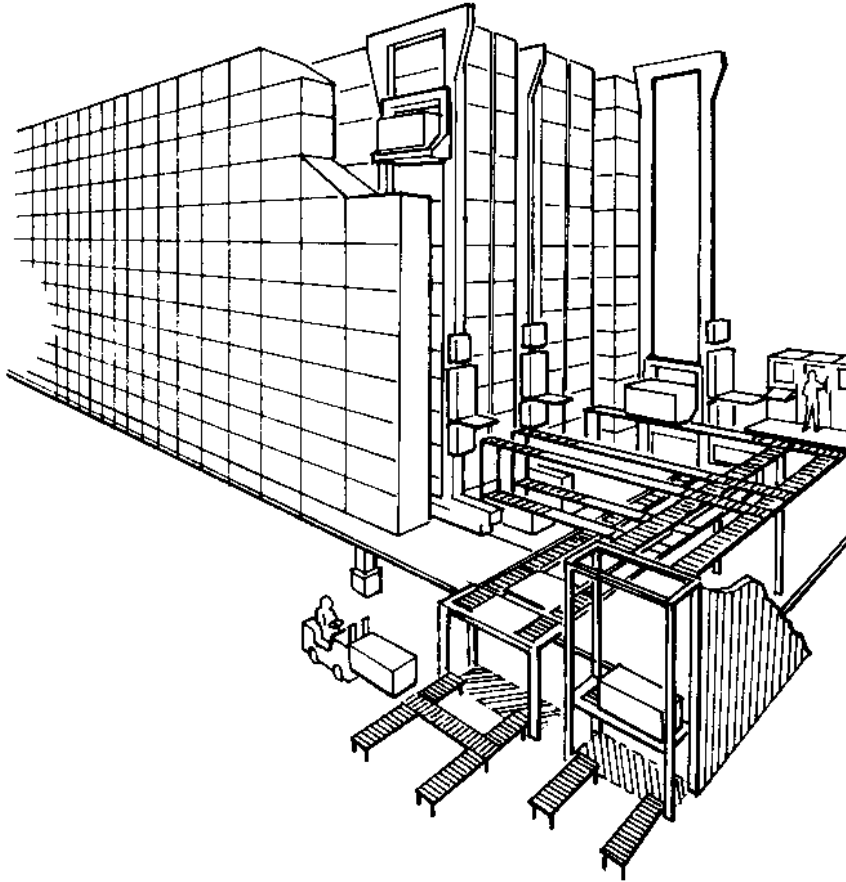

# Components and Terminology

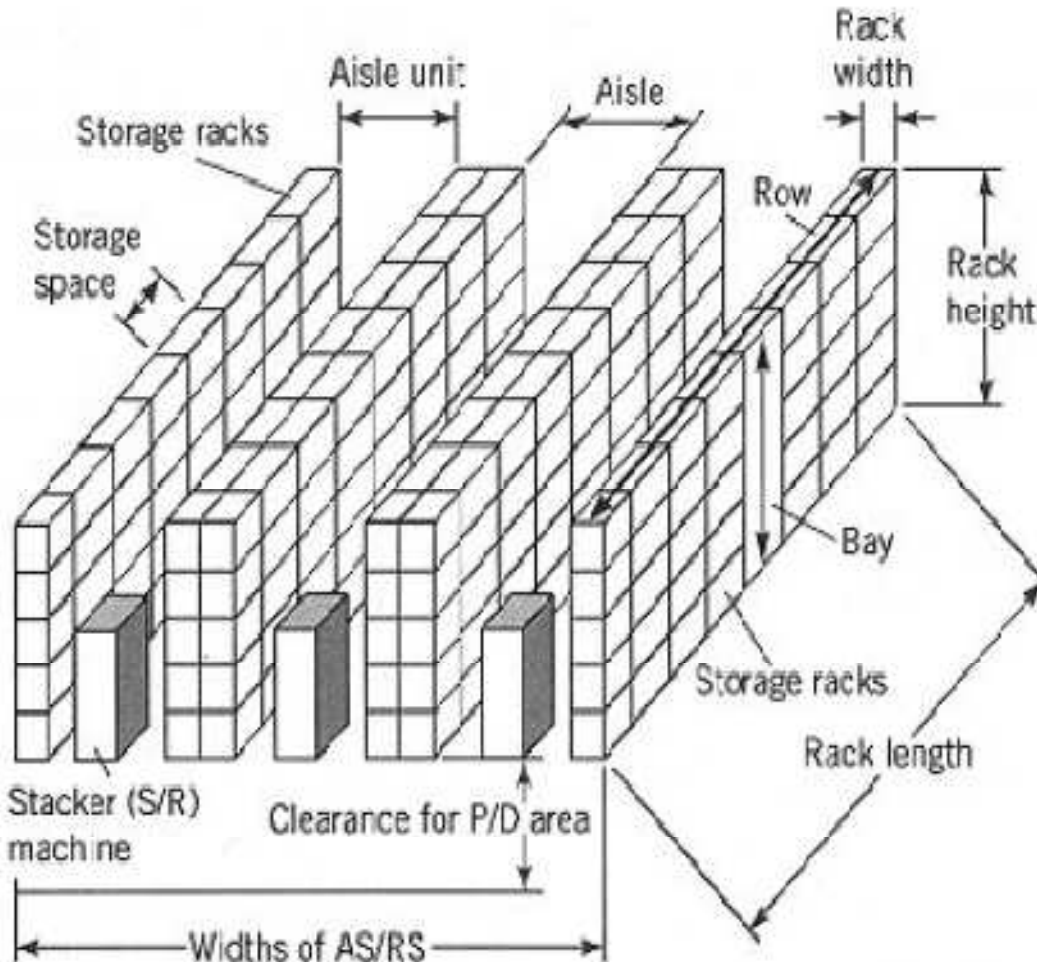

- Storage space
- Bay
- Row
- Aisle/Unit
- Racks
- S/R machine
- Storage modules

# Advantages

- Some advantages of using AS/RS are:
  - High space efficiency
  - Improved inventory management and control
  - Reduction in labor costs
  - Better security
  - Flexibility in design to accommodate various loads
  - Increased productivity when interfaced with other manufacturing systems like FMS etc
  - Helps JIT implementation

# Types of AS/RS

- Unit Load AS/RS
  - Multi Load AS/RS
  - Person on board AS/RS
  - Deep Lane AS/RS
  - Automated item retrieval system
- 

# Unit Load AS/RS

- Used for palletized/container loads with standard sizes
- Computerized and Automated
- Uses automated SR machines
- Uses rails for guidance

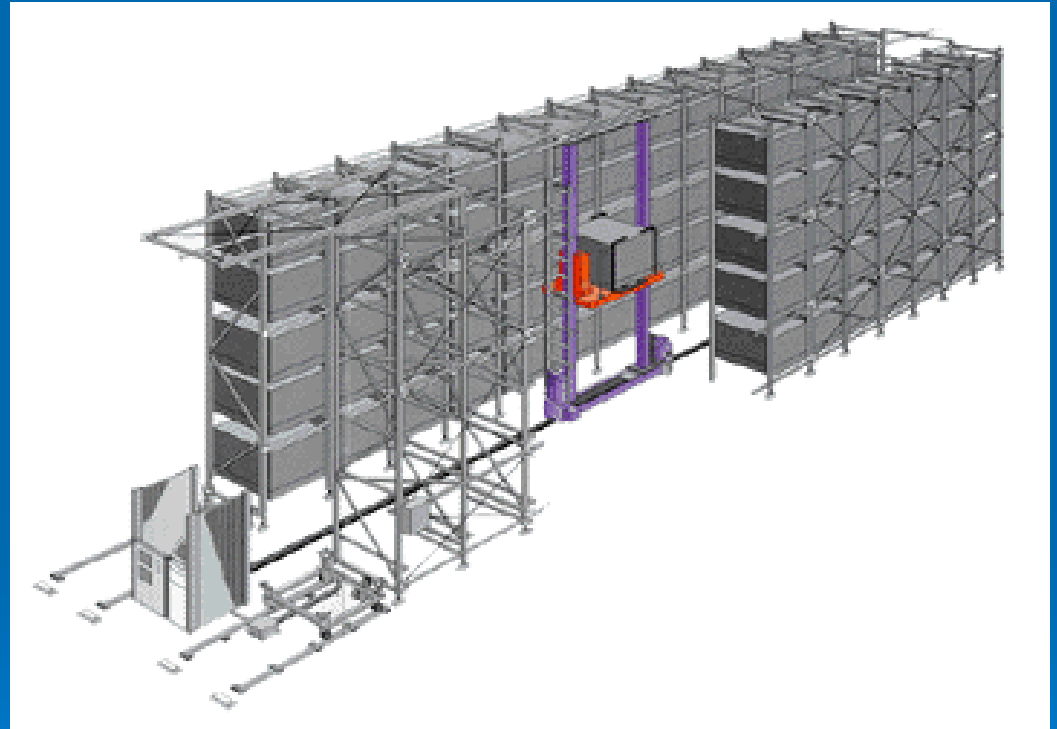

# Mini Load AS/RS

- Handling of small loads/  
individual parts
- Ideal for cases where  
space is limited
- Low volume productions
- Smaller investment and  
greater flexibility



# Person on Board AS/RS

- Allows storage of items in less than load quantities.
- Person performs tasks of selection and picking
- Flexibility and time reduction



# Design of AS/RS

- Determine load sizes:  $h \times l \times w$
- Determine dimensions of individual storage space

$$\text{Height} = h + c1$$

$$\text{Length} = l + c2$$

$$\text{Width} = u(w + c3)$$

- Determine number of storage spaces (dedicated vs random):
  - Depends on maximum or aggregate inventory levels.
  - Determine system throughput and no. of S/R machines:
  - System throughput = no. stored + no. retrieved per hour
  - No. of S/R machines = System throughput/S/R machine cap.
- Determine size parameters:
  - No. of rows in system = 2x No. of S/R machines
  - No. of bays = no. of storage spaces/no. of rows x no. of S/R x no. of
  - Storage spaces per system height
  - Bay width =  $l + c2 + c4$
  - Rack length = bay width x no. of bays
  - System length = rack length + clearance for S/R machine
  - clearance for the P/D area
  - Bay depth =  $u(w + c3) + c5$  (bay side support allowance)
  - Aisle unit = aisle width + (2 x bay depth)
  - System width = aisle unit x desired no. of aisles

# Design of AS/RS contd

- Determine utilization of S/R machines:
  - No of transactions per S/R per hour  $nt =$  System throughput/of S/R machines
  - System permits mix of single and dual command transactions ratio of  $\alpha + \beta = 1$ .
  - No. of storage and retrievals are equal in the long run.
  - Workload per machine =  $\alpha ntT_{sc} + \beta (nt/2)T_{dc}$  minutes/hour
  - The  $(nt/2)$  appears in the second term because in a dual-command both a storage and a retrieval are done in one cycle.